

Aflmeiri 60 riða landtenging

## Sérstaða þessa verkefnis.

- Mikið afl (500 kW)
- 50-60 rið
- Einangrunarspennir
- Sérhannaður krani til að koma aflstrengum til og frá borði

## Yfirlit yfir verkið.

- Helsti búnaður
- Uppbygging
- Virkni

## Helsti búnaður.

- Aflofaskápur (A1)
- Riðbreytir (PSC 100)
- Einangrunarspennir
- Stjórnskápur (A2)
- Strengkrani
- Stjórnskápur á bryggju (A3)
- Strenglagnir

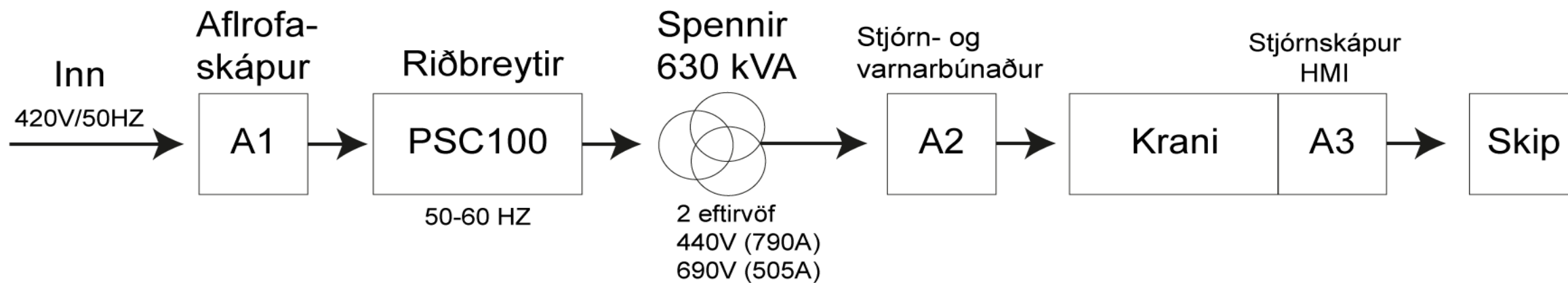

## Riðbreytir.

- ABB PCS 100 SFC
- Modular lausn
- Samanstendur af 4 einingum
- Breytir úr 50 Hz í 60 Hz
- Innkomandi spenna frá veitu 420V/50Hz
- Útgangsafl er 500 kW



## Einangrunarspennir.

- Þriggja vafa 630 kVA þurrspennir
- Forvaf 420 V
- Tvö eftirvöf 440 V og 690 V





## Stjórnskápur (A2).

- Aflstrengir inn frá spennni
- Aflstrengir út til krana
- Stjórn-og varnarbúnaður



## Strenglagnir milli spennis og strengkrana.

- Aflstrengir Cu 2x(4G240mm<sup>2</sup>)
- Skermaðir stýristrengir
- Lagnaleið um 60 m

HÖRMANN



SS  
690 440 V



TRASTOR

## Strengkrani.

- Krani kemur þremur strengjum með þremur tengiklóm til og frá borði
- Hæð 9m frá jörðu
- Þrjú strengir Cu 3(3x185+2G95+4x2,5)
- Tengiklær eru frá Cavotec 3 stk.
- Á krana er stjórnskápur með snertiskjá (A3)
- Hægt er að fjarstýra krana

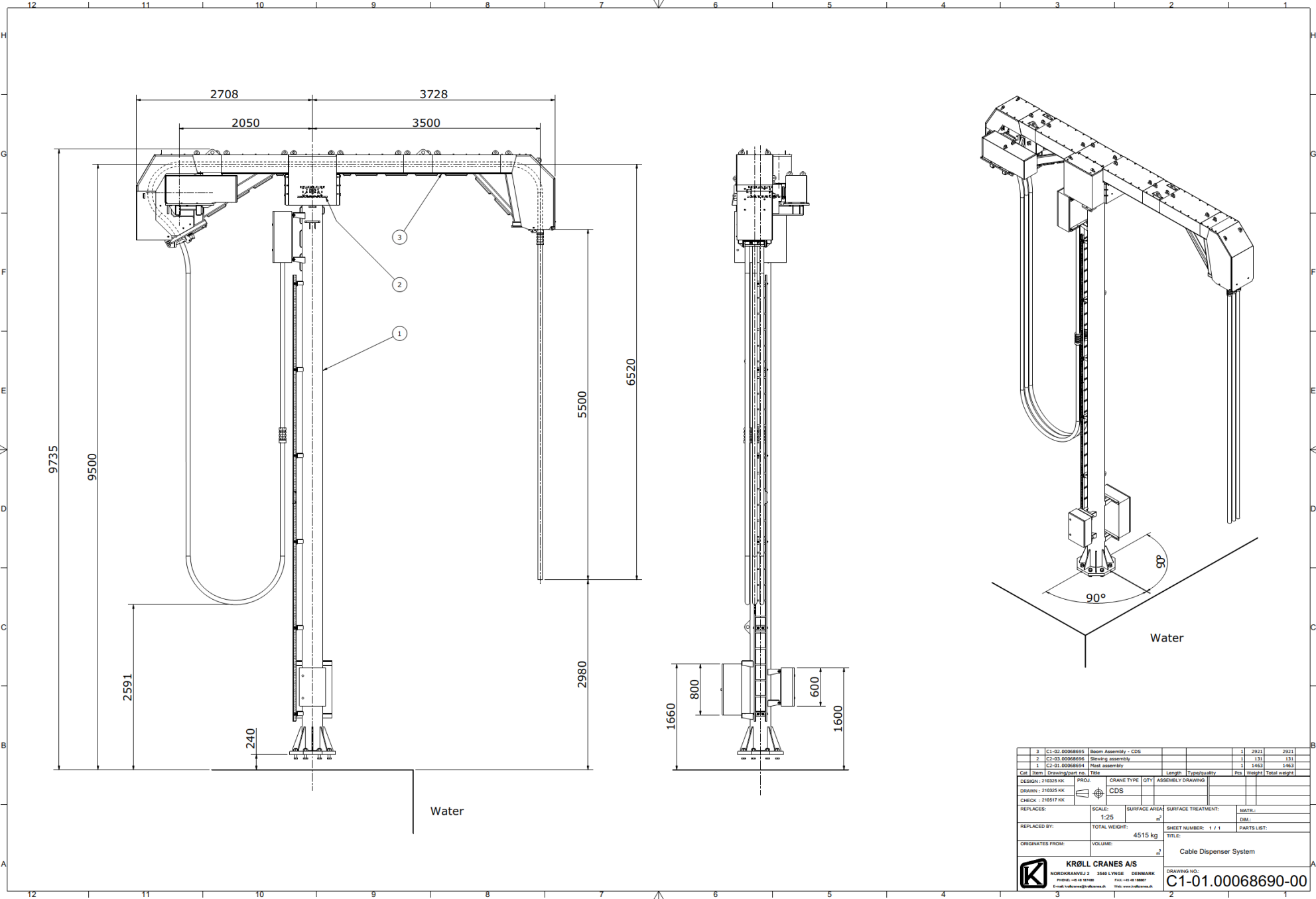

3	C1-01.00068695	Boom Assembly - CDS			1	2921	2921
2	C3-03.00068696	Slewing assembly			1	131	131
1	C2-01.00068694	Mast assembly			1	1463	1463
Call Sheet		Drawing/Part no.	Title	Length	Trans./quantity	Pcs	Weight/ Total weight
DESIGN:	210025 KK	PROJ.	CDS	CRANE TYPE	QTY	ASSEMBLY DRAWING	
DRAWN:	210025 KK						
CHECK:	210017 KK						
REPLACES:	SCALE:	SURFACE AREA:	SURFACE TREATMENT:	MATR.:			
	1:25	m <sup>2</sup>		DM:			
REPLACED BY:	TOTAL WEIGHT:	4515 kg	SHEET NUMBER:	1 / 1	PARTS LIST:		
ORIGINATES FROM:	VOLUME:	2	TITLE:	Cable Dispenser System			
		<b>KRÖLL CRANES A/S</b>		DRAWING NO.:		<b>C1-01.00068690-00</b>	
NORDKRANVEJ 2 3540 LYNØ DENMARK		FAX: +45 46 18 881		E-mail: info@kroell.com		www.kroell.com	

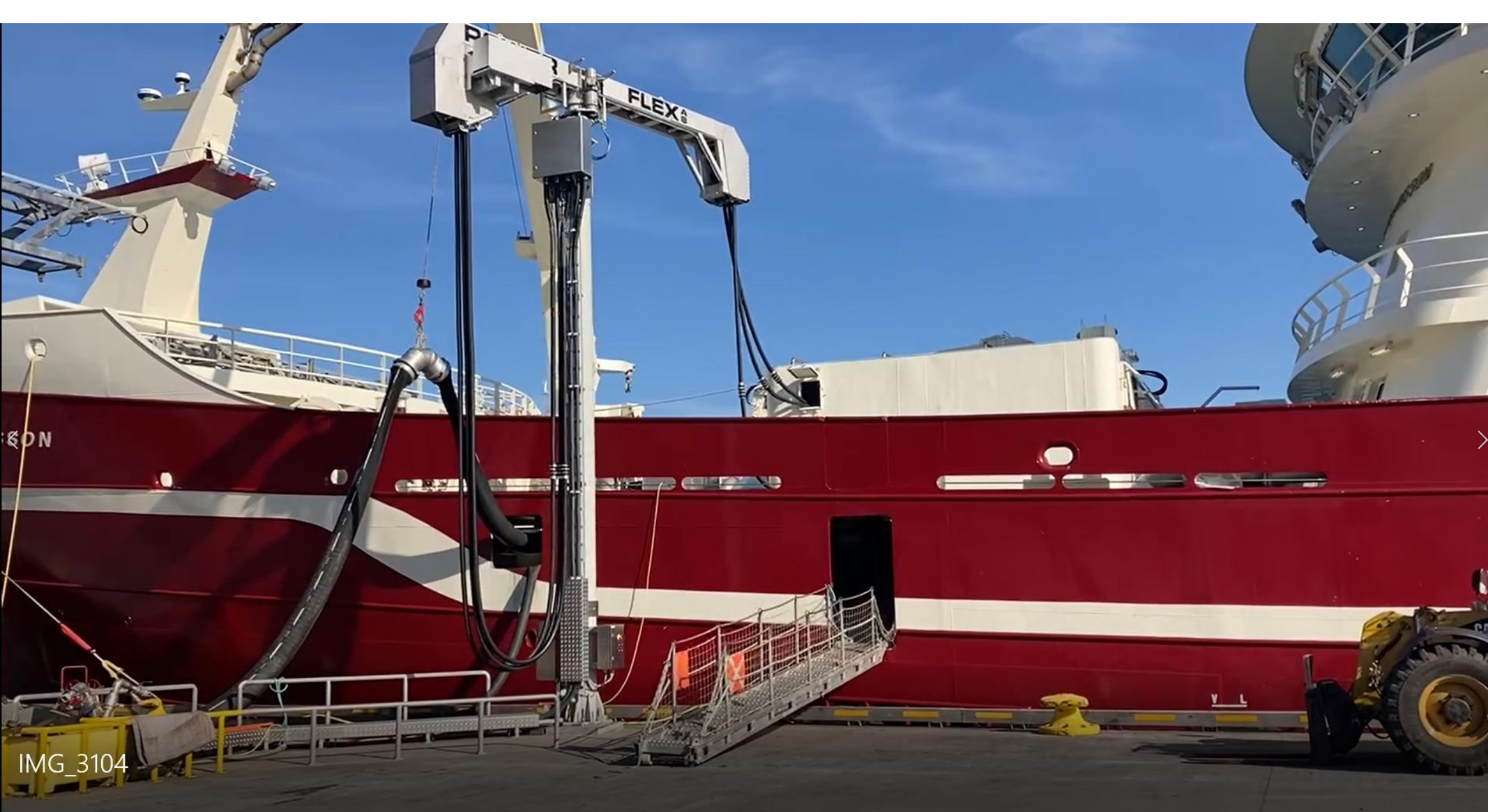

IMG\_3104







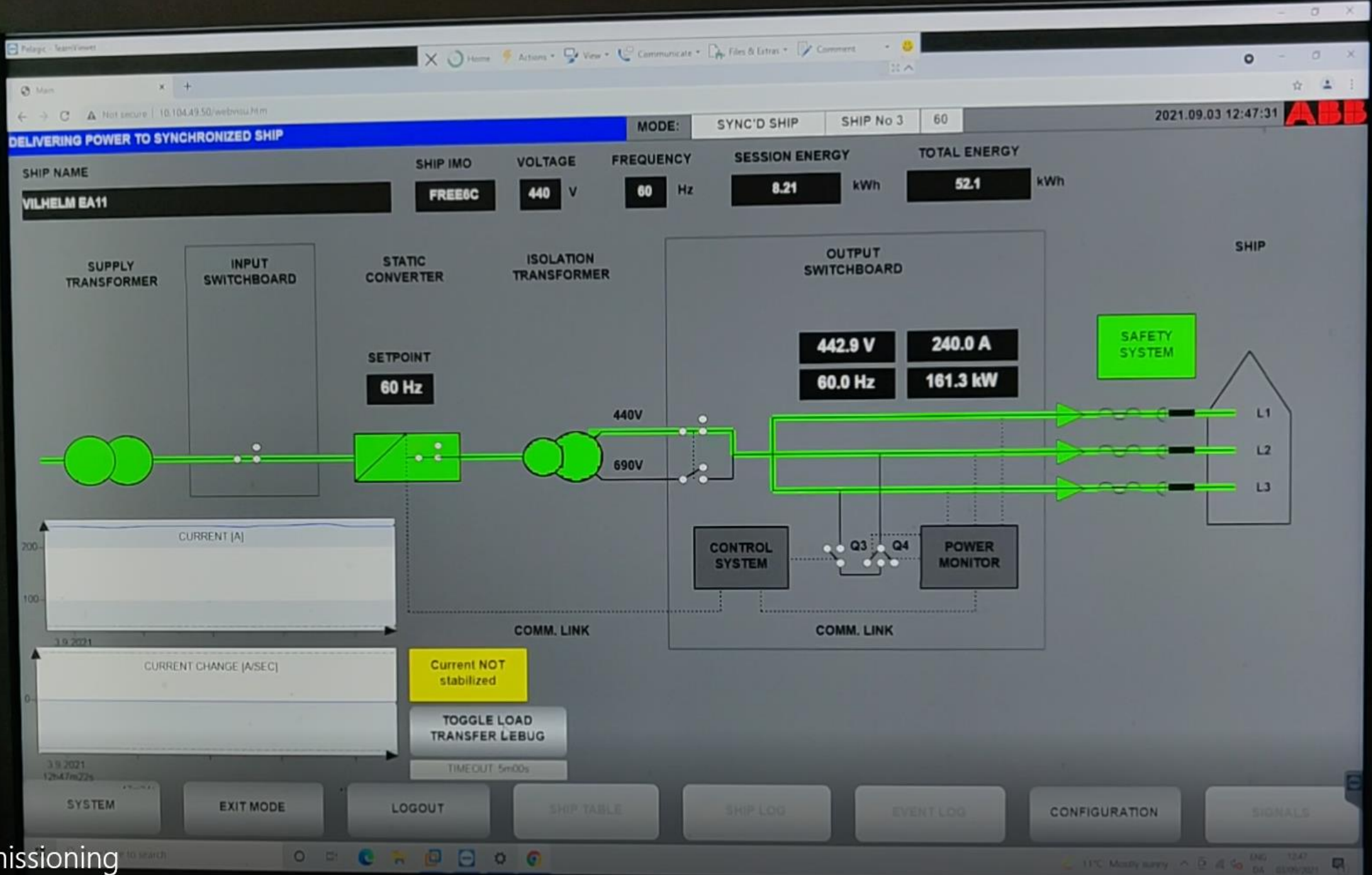

Remote Commissioning

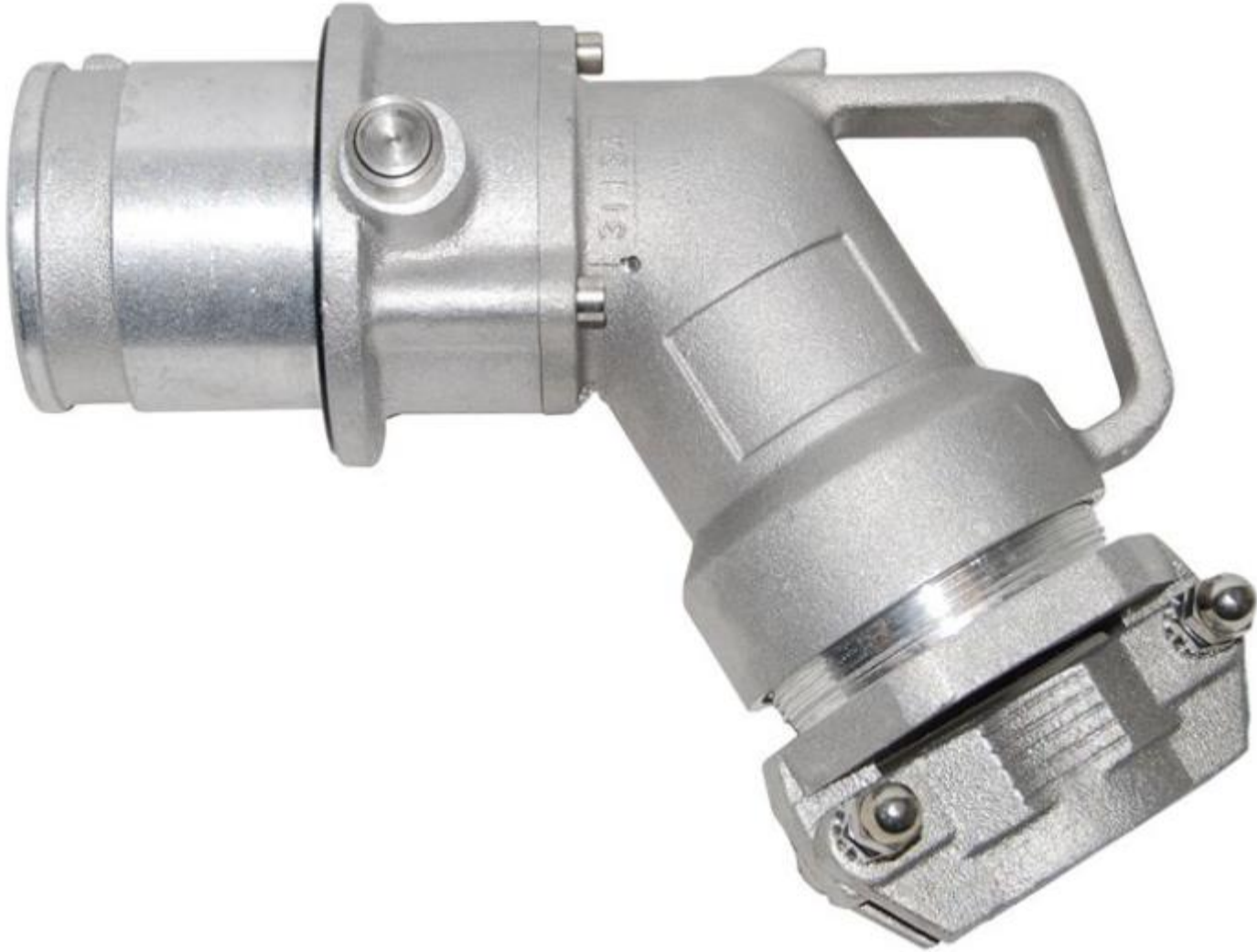

## Tengiskápur í skipi.

- Þrír tenglar frá Cavotec sem kranaklær tengjast
- Stjórn-og varnarbúnaður





Takk fyrir!